

# \*TB 9-6625-2342-24

## CALIBRATION PROCEDURE FOR OSCILLOSCOPE TEKTRONIX, MODEL 2430A

Headquarters, Department of the Army, Washington, DC  
3 October 2007

*Distribution Statement A: Approved for public release; distribution is unlimited.*

### REPORTING OF ERRORS AND RECOMMENDING IMPROVEMENTS

You can improve this manual. If you find any mistakes or if you know of a way to improve these procedures, please let us know. Mail your letter or DA Form 2028 (Recommended Changes to Publications and Blank Forms) directly to: Commander, U.S. Army Aviation and Missile Command, ATTN: AMSAM-MMC-MA-NP, Redstone Arsenal, AL 35898-5000. A reply will be furnished to you. You may also send in your comments electronically to our E-mail address: [2028@redstone.army.mil](mailto:2028@redstone.army.mil) or by fax 256-842-6546/DSN 788-6546. For the World Wide Web use: <https://amcom2028.redstone.army.mil>. Instructions for sending an electronic 2028 can be found at the back of this manual.

SECTION		Paragraph	Page
I.	IDENTIFICATION AND DESCRIPTION		
	Test instrument identification .....	1	2
	Forms, records, and reports.....	2	2
	Calibration description .....	3	2
II.	EQUIPMENT REQUIREMENTS		
	Equipment required.....	4	3
	Accessories required.....	5	3
III.	CALIBRATION PROCESS		
	Preliminary instructions .....	6	3
	Equipment setup .....	7	4
	Calibrator accuracy .....	8	5
	Vertical gain accuracy.....	9	6
	Bandwidth accuracy.....	10	8
	Internal and external trigger sensitivity accuracy .....	11	9
	Horizontal linearity accuracy.....	12	11
	Time cursor accuracy .....	13	13
IV.	ADJUSTMENTS		
	Calibration constants restoration .....	14	14
	Final procedure .....	15	17

\*This bulletin supersedes TB 9-6625-2342-35, dated 10 December 2003, including all changes.

**SECTION I  
IDENTIFICATION AND DESCRIPTION**

**1. Test Instrument Identification.** This bulletin provides instructions for the calibration of Oscilloscope Tektronix, Model 2430A. Manufacturers' manuals were used as the prime data sources in compiling these instructions. The equipment being calibrated will be referred to as the TI (test instrument) throughout this bulletin.

**a. Model Variations.** None.

**b. Time and Technique.** The time required for this calibration is approximately 5 hours, using the dc and low frequency technique.

**2. Forms, Records, and Reports**

**a.** Forms, records, and reports required for calibration personnel at all levels are prescribed by TB 750-25.

**b.** Adjustments to be reported are designated (R) at the end of the sentence in which they appear. When adjustments are in tables, the (R) follows the designated adjustment. Report only those adjustments made and designated with (R).

**3. Calibration Description.** TI parameters and performance specifications which pertain to this calibration are listed in table 1.

Table 1. Calibration Description

Test instrument parameters	Performance specifications
<u>Vertical</u> Deflection & Volts cursors	Range: 2 mV to 5 V/div Cursor accuracy: ± 2%
Bandwidth	Range: DC to 150 MHz
<u>Triggering</u> Internal A	Range: 1 div @ 150 MHz
Internal B	2 div @ 150 MHz
External A	50 mV @ 150 MHz
External B	100 mV @ 150 MHz
<u>Horizontal</u> Sweep (A&B)	Range: 5 ns to 0.5 s/div Accuracy: ± 1%
Time cursors	Range: ± 5 div from CRT center Accuracy: ± 1%
<u>Calibrator</u>	Range: 0.4 Vp-p Accuracy: ± 1%

**SECTION II  
EQUIPMENT REQUIREMENTS**

**4. Equipment Required.** Table 2 identifies the specific equipment to be used in this calibration procedure. This equipment is issued with Secondary Transfer Calibration Standards Set AN/GSM-286, AN/GSM-287, or AN/GSM-705. Alternate items may be used by the calibrating activity. The items selected must be verified to perform satisfactorily prior to use and must bear evidence of current calibration. The equipment must meet or exceed the minimum use specifications listed in table 2. The accuracies listed in table 2 provide a four-to-one ratio between the standard and TI. Where the four-to-one ratio cannot be met, the actual accuracy of the equipment selected is shown in parenthesis.

**5. Accessories Required.** The accessories required for this calibration are common usage accessories issued as indicated in paragraph 4 above and are not listed in this calibration procedure.

Table 2. Minimum Specifications of Equipment Required

Common name	Minimum use specifications	Manufacturer model (part number)
CALIBRATOR	Voltage output: Range: .000200 to 20 V dc Accuracy: ±0.25%	Fluke, Model 5720A (5720A) (p/o MIS-35947)
OSCILLOSCOPE CALIBRATOR	Voltage output: Range: 10 mV to 5 V Accuracy: ±0.25% Time markers: 0.5 ns to .5 s Leveled sine wave: Range: 10 mV to 3 V p-p Frequency: 10 Hz to 150 MHz Accuracy: ±0.25%	Fluke, Model 5820A-5C-GHZ (5820A-5C-GHZ)

**SECTION III  
CALIBRATION PROCESS**

**6. Preliminary Instructions**

**a.** The instructions outlined in paragraphs 6 and 7 are preparatory to the calibration process. Personnel should become familiar with the entire bulletin before beginning the calibration.

**b.** Items of equipment used in this procedure are referenced within the text by common name as listed in table 2.

**c.** Unless otherwise specified, verify the result of each test and, whenever the test requirement is not met, take corrective action before continuing with the calibration. Adjustments required to calibrate the TI are included in this procedure. Additional maintenance information is contained in the manufacturers' manuals for this TI.

**d.** Unless otherwise specified, all control and control settings refer to the TI.

## 7. Equipment Setup

### WARNING

HIGH VOLTAGE is used or exposed during the performance of this calibration. DEATH ON CONTACT may result if personnel fail to observe safety precautions. REDUCE OUTPUT(S) to minimum after each step within the performance checks where applicable.

- a. Ensure the **POWER-ON-OFF** pushbutton is in the **OFF** position (out).
- b. Connect TI to appropriate power source.
- c. Press **POWER-ON-OFF** pushbutton to **ON** (in) and allow 20 minutes for TI to warm-up and stabilize.
- d. Press **MENU OFF/EXTENDED FUNCTIONS** pushbutton once or twice.

### NOTE

Two presses are necessary if any menu is presently displayed and one press if no menu is displayed.

### NOTE

“Select” means to press appropriate front panel pushbutton to obtain a menu on CRT. “Set” means to press appropriate menu pushbutton located on lower portion of CRT bezel by underlining (turn on) or removing underline (turn off) desired menu selection.

- e. Set **CAL/DIAG**.
- f. Set **SELF CAL**.

### NOTE

**RUNNING** will be displayed in lower right corner of crt screen for approximately 10 seconds. Upon successful completion of self calibration, **PASS** will be displayed above **SELF CAL** menu pushbutton.

- g. Press **MENU OFF/EXTENDED FUNCTIONS** pushbuttons.
- h. If TI displays **EXTENDED DIAGNOSTICS** menu, repeat **d** through **g** above. If TI displays **EXTENDED DIAGNOSTICS** menu again, corrective action must be taken before continuing procedure.
- i. Select **TRIGGER MODE** and set **AUTO** to on.
- j. Select **VERTICAL MODE** and set **CH 2** to on.
- k. Select **CH 1 COUPLING/INVERT** and set **50 Ω ON/OFF COUPLING** to **ON**.
- l. Select **CH 2 COUPLING/INVERT** and set **50 Ω ON/OFF COUPLING** to **ON**.
- m. Set **A SEC/DIV** to **500 μs**.

- n. Press **A/B TRIG** button.
- o. Select **TRIGGER MODE** and set **TRIG AFTER** to **ON**.
- p. Press **A/B TRIG** button.
- q. Select **STORAGE ACQUIRE** and set **REPET ON: OFF** pushbutton to **ON**.
- r. Press **AVG** switch until **16** appears above **AVG**.
- s. Press **ENVELOPE** switch until **16** appears above **ENVELOPE**.
- t. Set **NORMAL** to on.
- u. Select **PRGM** to display **SEQUENCER** menu.
- v. Press **SAVE** in main menu to display **SAVE SEQUENCER** menu.

**NOTE**

Saving **FPNL** sequence will cause an error if a **FPNL** sequence is already stored. Clear the previous sequence by selecting **PRGM**, pressing **DELETE**, pressing the up/down arrows to select **FPNL**, then press **DELETE**.

- w. Use arrows under **ROLL-CHARS** to create a front panel setup label (use **FPNL** for the label).
- x. Use the up/down arrow switches to select first letter of label.
- y. When first letter is displayed press **CURSOR <>**.
- z. Repeat technique of **x** and **y** above until **FPNL** is spelled out, then press menu **SAVE** switch.
- aa. Depressing menu switch saves the label for the sequence and displays **SETUP CONTROLS PUSH PRGM** to **CONTINUE**. Select **TRIGGER MODE** and set **AUTO LEVEL**.
- ab. Press **PRGM** button then push **SAVE SEQ**.

**8. Calibrator Accuracy**

- a. Press **PRGM** button then press **RECALL** button in main menu.
- b. Use arrow labeled switches to underline **FPNL**.
- c. Press **RECALL** button.
- d. Select **VERTICAL MODE** and set **CH 2** to off.
- e. Select **CH 1 COUPLING/INVERT** and set **50 Ω ON/OFF** to **OFF**.
- f. Select **CH 2 COUPLING/INVERT** and set **50 Ω ON/OFF** to **OFF**.
- g. Select **BANDWIDTH** and set **20 MHz** to on.
- h. Set **CH 1 VOLTS/DIV** to **100 mV**.
- i. Connect **TI CALIBRATOR** output to **CH 1** input.

## TB 9-6625-2342-24

- j. Adjust TI **CH 1 VOLTS/DIV** and **VAR** controls for exactly 4 divisions of vertical display on CRT.
- k. Disconnect TI **CALIBRATOR** output from **CH 1** input.
- l. Connect oscilloscope calibrator **SOURCE/MEASURE CHAN 1** output to TI **CH 1** input connector.
- m. Set oscilloscope calibrator to a **VOLTAGE** output of **400 mV** and frequency of **500 Hz**.
- n. Adjust oscilloscope calibrator knob located below the **EDIT FIELD** key for exactly 4 divisions displayed on TI CRT. **Err** displayed on oscilloscope calibrator will be within  $\pm 1.0$  percent.
- o. Set oscilloscope calibrator output to minimum and disconnect equipment setup.
- p. Select **VAR** and set **CAL**.

### 9. Vertical Gain Accuracy

#### NOTE

If TI does not perform as specified, perform adjustments as indicated in **SECTION IV**.

- a. Connect oscilloscope calibrator **SOURCE/MEASURE CHAN 1** output to TI **CH 1** input connector, oscilloscope calibrator **SOURCE/MEASURE CHAN2** output to TI **CH 2** input connector.
- b. Rotate **CH 1 VOLTS/DIV** knob to set **CH 1** for **2 mV** indication in upper left portion of CRT.
- c. Set oscilloscope calibrator for a **CHAN 1, VOLTAGE** output of **10 mV** and frequency of **1 kHz**.
- d. Adjust TI **VERTICAL  $\updownarrow$  POSITION** control to align bottom of signal 3 divisions below CRT center graticule.
- e. Select **CURSOR FUNCTION** and set **VOLTS** to on.
- f. Rotate TI **CURSOR/DELAY** control to position selected cursor (segmented) with bottom of displayed signal.
- g. Select **CURSOR SELECT** and rotate **CURSOR/DELAY** control to position selected cursor with top of displayed signal. Display will indicate within limits specified in first row of table 3, cursor limit column.
- h. Select **TRIGGER MODE** and set **AUTO** to on.
- i. Rotate **TRIGGER LEVEL** control to the most positive voltage that produces a barely triggered jittering display. TI **A TRIGGER LEVEL** display will indicate within limits specified in first row of table 3, + Peak column.
- j. Select **TRIGGER SLOPE**.

- k. Rotate **TRIGGER LEVEL** control to the most positive voltage that produces a barely triggered jittering display. **TI A TRIGGER LEVEL** display will indicate within limits specified in first row of table 3, – Peak column.
- l. Select **TRIGGER SLOPE** and rotate **TRIGGER LEVEL** control for a stable display.
- m. Select **A/B TRIG** and select **HORIZ MODE B**.
- n. Rotate **TRIGGER LEVEL** control to the most positive voltage that produces a barely triggered jittering display. **TI B TRIGGER LEVEL** display will indicate within limits specified in first row of table 3, + Peak column.
- o. Select **TRIGGER SLOPE**.
- p. Rotate **TRIGGER LEVEL** control to the most positive voltage that produces a barely triggered jittering display. **TI B TRIGGER LEVEL** display will indicate within limits specified in first row of table 3, – Peak column.
- q. Select **TRIGGER SLOPE**.
- r. Select **HORIZ MODE B** and select **A/B TRIG**.
- s. Select **TRIGGER MODE** and set **AUTO LEVEL** to on.
- t. Repeat technique of **b** through **s** above for remaining oscilloscope calibrator outputs and TI settings in table 3. TI display will indicate within limits specified in table 3.

Table 3. Vertical Gain and Volts Cursor Accuracy CH 1

Oscilloscope calibrator	Test instrument						
	VOLTS/ DIV	Cursor limits		+ Peak limits		– Peak limits	
		Min	Max	Min	Max	Min	Max
10 mV	2 mV	9.72 mV	10.28 mV	8.5 mV	11.5 mV	1.2 mV	-1.2 mV
20 mV	5 mV	19.40 mV	20.60 mV	17.2 mV	22.8 mV	2.2 mV	-2.2 mV
50 mV	10 mV	48.60 mV	51.40 mV	44.4 mV	55.6 mV	4.0 mV	-4.0 mV
.1 V	20 mV	97.20 mV	102.80 mV	89.6 mV	110.4 mV	7.2 mV	-7.2 mV
.2 V	50 mV	194.0 mV	206.0 mV	178.0 mV	222.0 mV	16.0 mV	-16.0 mV
.5 V	.1 V	486.0 mV	514.0 mV	448.0 mV	552.0 mV	36.0 mV	-36.0 mV
1 V	.2 V	972 mV	1.03 V	896 mV	1.10 V	72.0 mV	-72.0 mV
2 V	.5 V	1.94 V	2.06 V	1.8 V	2.2 V	160 mV	-160 mV
5 V	1 V	4.86 V	5.14 V	4.5 V	5.5 V	360 mV	-360 mV
10 V	2 V	9.72 V	10.28 V	9.0 V	11.0 V	710 mV	-710 mV
20 V	5 V	19.4 V	20.6 V	17.8 V	22.2 V	1.6 V	-1.6 V

- u. Select **VERTICAL MODE** and set **CH 2** to on.
- v. Select **VERTICAL MODE** and set **CH 1** to off.
- w. Rotate **CH 2 VOLTS/DIV** knob to set **CH 2** for a **2 mV** indication in upper left portion of CRT.
- x. Set oscilloscope calibrator for a **CHAN 2, VOLTAGE** output of **10 mV** and frequency of **1 kHz**.

**TB 9-6625-2342-24**

y. Repeat technique of **d** through **s** above for oscilloscope calibrator outputs and TI settings in table 4. TI display will indicate within limits specified in table 4.

Table 4. Vertical Gain and Volts Cursor Accuracy CH 2

Oscilloscope calibrator Output	Test instrument						
	VOLTS/ DIV	Cursor limits		+ Peak limits		- Peak limits	
		Min	Max	Min	Max	Min	Max
10 mV	2 mV	9.72 mV	10.28 mV	8.5 mV	11.5 mV	1.2 mV	-1.2 mV
20 mV	5 mV	19.40 mV	20.60 mV	17.2 mV	22.8 mV	2.2 mV	-2.2 mV
50 mV	10 mV	48.60 mV	51.40 mV	44.4 mV	55.6 mV	4.0 mV	-4.0 mV
.1 V	20 mV	97.20 mV	102.80 mV	89.6 mV	110.4 mV	7.2 mV	-7.2 mV
.2 V	50 mV	194.0 mV	206.0 mV	178.0 mV	222.0 mV	16.0 mV	-16.0 mV
.5 V	.1 V	486.0 mV	514.0 mV	448.0 mV	552.0 mV	36.0 mV	-36.0 mV
1 V	.2 V	972 mV	1.03 V	896 mV	1.10 V	72.0 mV	-72.0 mV
2 V	.5 V	1.94 V	2.06 V	1.8 V	2.2 V	160 mV	-160 mV
5 V	1 V	4.86 V	5.14 V	4.5 V	5.5 V	360 mV	-360 mV
10 V	2 V	9.72 V	10.28 V	9.0 V	11.0 V	710 mV	-710 mV
20 V	5 V	19.4 V	20.6 V	17.8 V	22.2 V	1.6 V	-1.6 V

z. Set oscilloscope calibrator output to minimum.

aa. Rotate **CH 2 VOLTS/DIV** control to set **CH 2** for a **1 V** indication on CRT.

ab. Rotate **CURSOR/DELAY** control to position active cursor 3 divisions above CRT horizontal centerline.

ac. Select **CURSOR SELECT** and rotate **CURSOR/DELAY** control to position active cursor 3 divisions below CRT horizontal centerline. **CURSOR VOLTS** readout will indicate between 5.94 V and 6.06 V.

**10. Bandwidth Accuracy**

**NOTE**

If TI does not perform as specified, perform adjustments as indicated in **SECTION IV**.

a. Press **PRGM** button then press **RECALL** button in main menu.

b. Use arrow labeled switches to underline **FPNL**.

c. Press **RECALL** button.

d. Select **VERTICAL MODE** and set **CH 2** to off.

e. Rotate **CH 1 VOLTS/DIV** knob to set **CH 1** for a **5 mV** indication on CRT. Adjust **HORIZONTAL A AND B SEC/DIV** controls for **5 μs** indications on CRT.

f. Set oscilloscope calibrator output for **CHAN 1, LEVEL SINE** output frequency of 50 kHz and amplitude for 6 divisions peak-to-peak signal on TI CRT. Adjust **TRIGGER LEVEL** control as necessary to obtain a stable display.



g. Adjust **LEVEL SINE** wave frequency until peak-to-peak signal on TI CRT decreases to 4.2 divisions. Adjust **TRIGGER LEVEL** control and **HORIZONTAL A AND B SEC/DIV** controls as necessary to obtain a stable display. **LEVEL SINE** frequency will be 150 MHz or greater.

h. Repeat technique of f and g above for settings listed in table 5 below. **LEVEL SINE** frequency will be within tolerance listed.

Table 5. Channel 1 Vertical Bandwidth Accuracy

Test instrument	Oscilloscope calibrator	
CH1 VOLTS/DIV settings	LEVEL SINE amplitude settings	LEVEL SINE frequency tolerance (≥)
5 mV	30 mV	150 MHz
10 mV	60 mV	150 MHz
20 mV	120 mV	150 MHz
50 mV	300 mV	150 MHz
100 mV	600 mV	150 MHz
200 mV	1.2 V	150 MHz
500 mV	3 V	150 MHz

i. Set oscilloscope calibrator to standby. Select **VERTICAL MODE**, set **CH 1** to off and set **CH 2** to on. Select oscilloscope calibrator **CHAN 2** out.

j. Repeat technique of e through g above for **CH 2** with settings listed in table 6 below. Leveled sine wave frequency will be within tolerance listed.

Table 6. Channel 2 Vertical Bandwidth Accuracy

Test instrument	Oscilloscope calibrator	
CH2 VOLTS/DIV settings	LEVEL SINE amplitude settings	LEVEL SINE frequency tolerance (≥)
5 mV	30 mV	150 MHz
10 mV	60 mV	150 MHz
20 mV	120 mV	150 MHz
50 mV	300 mV	150 MHz
100 mV	600 mV	150 MHz
200 mV	1.2 V	150 MHz
500 mV	3 V	150 MHz

k. Set oscilloscope calibrator to standby and disconnect equipment setup.

### 11. Internal and External Trigger Sensitivity Accuracy

#### NOTE

If TI does not perform as specified, perform adjustments as indicated in **SECTION IV**.

a. Press **PRGM** button then press **RECALL** button in main menu.

b. Use arrow labeled switches to underline **FPNL**.

**TB 9-6625-2342-24**

- c. Press **RECALL** button.
- d. Select **VERTICAL MODE** and set **CH 2** to off.
- e. Select **CH 1 COUPLING/INVERT** and set **50 Ω ON/OFF** to off.
- f. Select **CH 2 COUPLING/INVERT** and set **50 Ω ON/OFF** to off.
- g. Select **TRIGGER MODE** and set **AUTO** to on.
- h. Select oscilloscope calibrator **CHAN 1**, and connect oscilloscope calibrator **SOURCE/MEASURE CHAN 1** output through a 50Ω feedthrough termination to a BNC dual input coupler. Connect one end of BNC dual input coupler to the **TI CH1** input and leave remaining end of BNC dual input coupler unconnected.
- i. Adjust **HORIZONTAL A AND B SEC/DIV** controls for **5 ns** indications on CRT. Rotate **CH 1 VOLTS/DIV** knob for **100 mV** indications on CRT display.
- j. Set oscilloscope calibrator for a **CHAN 1, LEVEL SINE** output frequency of **150 MHz** and adjust oscilloscope calibrator knob located below the **EDIT FIELD** key on the oscilloscope calibrator for 1.0 divisions peak-to-peak signal displayed on TI CRT.
- k. Adjust **LEVEL** control for a stable display (**TRIG'D** light illuminated and **READY** light extinguished). Stable display will be observed.
- l. Select **A/B TRIGGER**.
- m. Select **HORIZONTAL MODE B** and adjust oscilloscope calibrator knob located below the **EDIT FIELD** key on the oscilloscope calibrator for 1.0 divisions peak-to-peak signal displayed on TI CRT.
- n. Adjust **LEVEL** control for a stable display (**TRIG'D** light illuminated and **READY** light extinguished). Stable display will be observed.
- o. Select **TRIGGER SOURCE** and set **EXT** then set **SOURCE 1|2** to 1. Connect unconnected end of BNC input coupler to **EXT TRIG 1**.
- p. Rotate **CH 1 VOLTS/DIV** knob for **50 mV** indications on CRT display.
- q. Set oscilloscope calibrator for a **CHAN 1, LEVEL SINE** output frequency of 150 MHz and output amplitude of 100 mV.
- r. Adjust **LEVEL** control for a stable display (**TRIG'D** light illuminated and **READY** light extinguished). Stable display will be observed.
- s. Move BNC dual input coupler connection from **EXT TRIG 1** to **EXT TRIG 2** and perform (1) through (3) below:
  - (1) Select **TRIGGER SOURCE**.
  - (2) Set **EXT**.
  - (3) Set **SOURCE 1|2** to 2.
- t. Adjust **LEVEL** control for a stable display (**TRIG'D** light illuminated and **READY** light extinguished). Stable display will be observed.
- u. Select **HORIZONTAL MODE A** then select **A/B TRIG**.

- v. Select **TRIGGER SOURCE**, set **EXT** then set **SOURCE 1 | 2** to **2**.
- w. Set oscilloscope calibrator for a **CHAN 1, LEVEL SINE** output frequency of 150 MHz and output amplitude of 50 mV.
- x. Adjust **LEVEL** control for a stable display (**TRIG'D** light illuminated and **READY** light extinguished). Stable display will be observed.
- y. Move BNC dual input coupler connection from **EXT TRIG 2** to **EXT TRIG 1** and perform (1) through (3) below:
  - (1) Select **TRIGGER SOURCE**.
  - (2) Set **EXT**.
  - (3) Set **SOURCE 1 | 2** to **1**.
- z. Adjust **LEVEL** control for a stable display (**TRIG'D** light illuminated and **READY** light extinguished). Stable display will be observed.
- aa. Set oscilloscope calibrator to standby and disconnect equipment setup.

## 12. Horizontal Linearity Accuracy

### NOTE

If TI does not perform as specified, perform adjustments as indicated in **SECTION IV**.

- a. Press **PRGM** button then press **RECALL** button in main menu.
- b. Use arrow labeled switches to underline **FPNL**.
- c. Press **RECALL** button.
- d. Select: **VERTICAL MODE**. Set: **CH 2** to off.
- e. Rotate **CH 1 VOLTS/DIV** knob for **500 mV** indication on CRT display.
- f. Connect oscilloscope calibrator **SOURCE/MEASURE CHAN 1** output to TI **CH 1** input.
- g. Rotate **HORIZONTAL A AND B SEC/DIV** control for 200 ns indications on CRT.
- h. Set oscilloscope calibrator for **CHAN 1, MARKER** output of 200 ns.
- i. Rotate **TRIGGER LEVEL** knob as necessary for triggered display.
- j. Rotate **HORIZONTAL ⇄ POSITION ⇄** control to align 3<sup>rd</sup> marker with 3<sup>rd</sup> graticule line. Adjust oscilloscope calibrator knob located under the **EDIT FIELD** key to align 9<sup>th</sup> marker with 9<sup>th</sup> graticule line. Markers will be within display tolerance listed in first row of table 7.
- k. Repeat technique of **g** through **j** above for remaining TI settings and oscilloscope calibrator outputs listed in table 7. Markers will be within display tolerance listed in table 7.

Table 7. MODE A Horizontal Linearity Accuracy

Oscilloscope calibrator		Test instrument		
MARKER output		A AND B SEC/DIV setting		Display tolerance (%)
0.2	μs/div	200	ns/div	± 1.0
0.5	μs/div	500	ns/div	± 1.0
1	μs/div	1	μs/div	± 1.0
2	μs/div	2	μs/div	± 1.0
5	μs/div	5	μs/div	± 1.0
10	μs/div	10	μs/div	± 1.0
20	μs/div	20	μs/div	± 1.0
50	μs/div	50	μs/div	± 1.0
.1	ms/div	100	μs/div	± 1.0
.2	ms/div	200	μs/div	± 1.0
.5	ms/div	500	μs/div	± 1.0
1	ms/div	1	ms/div	± 1.0
2	ms/div	2	ms/div	± 1.0
5	ms/div	5	ms/div	± 1.0
10	ms/div	10	ms/div	± 1.0
20	ms/div	20	ms/div	± 1.0
50	ms/div	50	ms/div	± 1.0
.1	s/div	100	ms/div	± 1.0
.2	s/div	200	ms/div	± 1.0
.5	s/div	500	ms/div	± 1.0

**NOTE**

Ensure **A AND B SEC DIV** settings remain locked.

- l. Rotate **HORIZONTAL A AND B SEC/DIV** control for 200 ns indications on CRT.
- m. Select: **HORIZONTAL MODE B** and set: **TRIGGER MODE** to **AUTO**.
- n. Select: **TRIGGER MODE**. Set: **RUNS AFTER** to **ON**.
- o. Use technique of **g** through **k** above for settings listed in table 8.

Table 8. MODE B Horizontal Linearity Accuracy

Oscilloscope calibrator		Test instrument		
MARKER output		A AND B SEC/DIV setting		Display Tolerance (%)
0.2	μs/div	200	ns/div	± 1.0
0.5	μs/div	500	ns/div	± 1.0
1	μs/div	1	μs/div	± 1.0
2	μs/div	2	μs/div	± 1.0
5	μs/div	5	μs/div	± 1.0

10	μs/div	10	μs/div	± 1.0
Table 8. MODE B Horizontal Linearity Accuracy - Continued				
20	μs/div	20	μs/div	± 1.0
50	μs/div	50	μs/div	± 1.0
.1	ms/div	100	μs/div	± 1.0
.2	ms/div	200	μs/div	± 1.0
.5	ms/div	500	μs/div	± 1.0
1	ms/div	1	ms/div	± 1.0
2	ms/div	2	ms/div	± 1.0
5	ms/div	5	ms/div	± 1.0
10	ms/div	10	ms/div	± 1.0
20	ms/div	20	ms/div	± 1.0
50	ms/div	50	ms/div	± 1.0
.1	s/div	100	ms/div	± 1.0
.2	s/div	200	ms/div	± 1.0
.5	s/div	500	ms/div	± 1.0

p. Set oscilloscope calibrator to standby and disconnect equipment setup.

**13. Time Cursor Accuracy**

- a. Press **PRGM** button then press **RECALL** button in main menu.
- b. Use arrow labeled switches to underline **FPNL**.
- c. Press **RECALL** button.
- d. Rotate **CH 1 VOLTS/DIV** knob for a **1 V** indication on CRT display.
- e. Rotate **CH 2 VOLTS/DIV** knob for a **2 V** indication on CRT display.
- f. Select **CURSOR FUNCTION** and set **TIME**.
- g. Rotate **CURSOR/DELAY** control to align active cursor to 3<sup>rd</sup> vertical graticule line.
- h. Select **CURSOR SELECT**.
- i. Rotate **CURSOR/DELAY** control to align active cursor to 9<sup>th</sup> vertical graticule line.
- j. TI cursor time readout will indicate between 2.9700 and 3.0300 ms.
- k. Select **HORIZONTAL MODE B** (do not change cursor position).
- l. TI cursor time readout will indicate between 2.9700 and 3.0300 ms.
- m. Set all outputs to minimum and disconnect equipment setup.

## SECTION IV ADJUSTMENTS

### 14. Calibration Constants Restoration

#### WARNING

HIGH VOLTAGE is used or exposed during the performance of this calibration. DEATH ON CONTACT may result if personnel fail to observe safety precautions. REDUCE OUTPUT(S) to minimum after each step within the performance check where applicable.

- a. Press **POWER-ON-OFF** pushbutton to **OFF** (out) and remove the cabinet from test instrument. Remove jumper J156 (fig. 1) from P156 on side board (located on right side of instrument near rear).

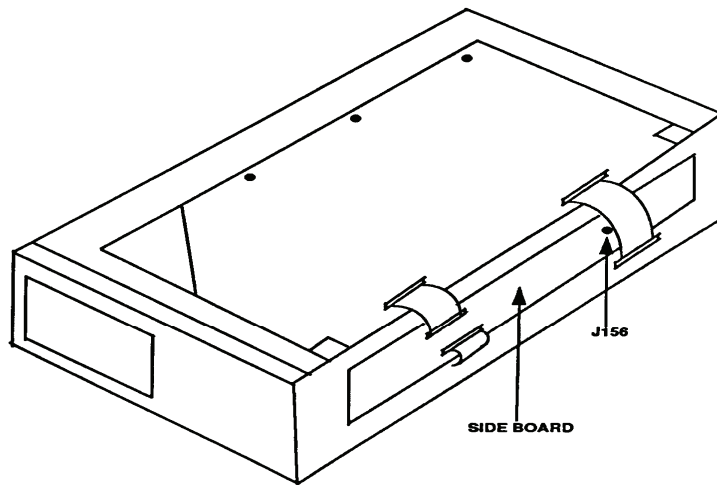

Figure 1. Test instrument jumper location (cabinet removed).

#### CAUTION

Operation of TI with the cabinet removed may cause damage to electrical components in the test instrument.

- b. Replace cabinet on TI.
- c. Connect TI to ac power source.

**NOTE**

When **POWER-ON-OFF** pushbutton is pressed to **ON** (in), a set of power-up tests are performed for several seconds. Upon successful completion of power-up tests, TI will enter **ACQUIRE** or **SAVE** mode, depending on mode in effect when power was removed, and be ready for operation. If an error is encountered during power-up tests, an "Extended Diagnostics" menu is displayed indicating corrective action is needed before proceeding with this procedure. Once power is on, this procedure must be completed without pressing TI **POWER-ON-OFF** switch to **OFF** (out).

- d. Press **POWER-ON-OFF** pushbutton to **ON** (in), and allow 20 minutes for equipment to warm-up and stabilize.

**NOTE**

Throughout this procedure, pressing certain pushbuttons will cause various options to be displayed on lower portion of TI crt.

- e. Press and release **MENU OFF/EXTENDED FUNCTIONS** pushbutton to display **EXT FUNCT** options on crt. If options are not displayed, press and release the same pushbutton a second time to display options.

**NOTE**

Pressing pushbuttons directly under options displayed on crt will set (underline) turn on or (remove underline) turn off options.

- f. Set **CAL/DIAG** and set **SELF DIAG**.

**NOTE**

Message **RUNNING** will appear on crt. Upon successful completion of self diagnostics cycle, message **RUNNING** will be replaced by message **PASS** above **SELF DIAG** option. Crt will be blank for 15 to 20 seconds.

- g. Press and release **MENU OFF/EXTENDED FUNCTIONS** pushbutton.
- h. Press and release **MENU OFF/EXTENDED FUNCTIONS** pushbutton two times to display **EXT FUNCT** options on crt.
- i. Set **CAL/DIAG** option on CRT.

**NOTE**

CRT may display a **PASS** indication for **SELF CAL** option. Step **o** below should still be performed to update stored information and prepare test instrument to respond to further testing.

**TB 9-6625-2342-24**

j. Set **SELF CAL**. Crt will display message **RUNNING**. After 10 to 15 seconds message will be replaced by **PASS** directly above **SELF CAL** option.

k. Press and release **MENU OFF/EXTENDED FUNCTION** pushbutton two times to display **EXT FUNCT** options on crt.

l. Set **CAL/DIAG** to display options on crt.

m. Set **EXT CAL** to display options on crt.

n. Set **ATTEN** and perform (1) through (8) below to establish attenuator gain **DAC** voltage reference levels.

(1) Crt will display message **CONNECT CH 1 TO 0.2 VDC**.

(2) Set calibrator (Fluke, Model 5720A) to 0 V output and connect to **TI CH 1** input.

(3) Set calibrator (Fluke, Model 5720A) for 0.200 V output.

(4) Set **ATTEN**. Crt will display message **RUNNING**. After approximately 3 to 5 seconds message will change to **CONNECT CH 1 to 2.0 VDC**.

(5) Set calibrator (Fluke, Model 5720A) for 2.00 V output and set **ATTEN**. Crt will display message **RUNNING**. After approximately 3 to 5 seconds message will change to **CONNECT CH 1 TO 20 VDC**.

(6) Set calibrator (Fluke, Model 5720A) for 20 V and set **ATTEN**. Crt will display message **RUNNING**. After approximately 3 to 5 seconds message will change to **CONNECT CH 2 TO 0.2 VDC**.

(7) Set calibrator (Fluke, Model 5720A) for 0 V output and to standby mode and move connection on TI from **CH 1** input connector to **CH 2** input connector.

(8) Repeat technique of (3) through (6) above for **CH 2**, changing calibrator (Fluke, Model 5720A) to appropriate settings.

**NOTE**

After successful completion of above sequence, crt will display **PASS** message above option **ATTEN**. If a **FAIL** message is displayed, verify test setup and repeat **n** (1) through (8) above. If **FAIL** message is still displayed, corrective action is necessary.

(9) Crt will display message **PASS** above option **ATTN**. Disconnect test setup.

o. Perform (1) through (6) below to establish trigger circuit DAC voltage reference level.

(1) Set **TRIGGER**. Crt will display message **CONNECT TRIGS TO GND**.

(2) Set calibrator (Fluke, Model 5720A) for 0 V output and connect to **TI EXT TRIG 1** and **EXT TRIG 2** through dual input coupler.

(3) Set calibrator (Fluke, Model 5720A) for 0.000200 V output. Set **TRIGGER**. Crt will display message **RUNNING**. After approximately 3 to 5 seconds crt will display message **CONNECT...TO 0.5 V**.



(4) Set calibrator (Fluke, Model 5720A) for 0.500 V and set **TRIGGER**. Crt will display message **RUNNING**. After approximately 3 to 5 seconds crt will display message **CONNECT...TO 2.0 V**.

(5) Set calibrator (Fluke, Model 5720A) for 2.00 V and set **TRIGGER**. Crt will display message **RUNNING**.

**NOTE**

After successful completion of above sequence, crt will display **PASS** message above option **TRIGGER**. If a **FAIL** is displayed, verify test setup and repeat (1) through (5) above. If **FAIL** message is still displayed, corrective action is necessary.

(6) Crt will display message **PASS** and above option **TRIGGER**. Disconnect test setup.

p. Perform (1) through (4) below for ramp (REPET).

**NOTE**

**REPET** calibration adjusts timing of jitter correction amplifiers so that waveform samples are correctly placed with respect to trigger point in repetitive acquisition mode.

(1) Press **MENU OFF/EXTENDED FUNCTIONS** pushbutton two times.

(2) Set **CAL/DIAG**.

(3) Set **EXT CAL** to display **EXT CAL** menu.

(4) Set **REPET**. Crt will display **RUNNING** and then display **PASS** or **FAIL**. If **PASS** is displayed calibration is complete; if display changes to **FAIL**, corrective action is needed.

**NOTE**

With jumper J156 (fig. 1) removed, calibration constants stored in TI firmware will be lost when power is applied and must be reestablished by performing this procedure completely.

q. Perform (1) through (3) below to prevent calibration constants from being lost.

(1) Press TI **POWER-ON-OFF** switch to **OFF** (out) and remove cabinet from TI.

(2) Replace jumper (J156) (fig. 1) on P156 on side board (located on right side of instrument near rear panel).

(3) Replace cabinet on TI.

**15. Final Procedure**

a. Deenergize and disconnect all equipment.

b. Annotate and affix DA label/form in accordance with TB 750-25.



By Order of the Secretary of the Army:

Official:



JOYCE E. MORROW

*Administrative Assistant to the  
Secretary of the Army*

0722108

GEORGE W. CASEY, JR.  
*General, United States Army  
Chief of Staff*

Distribution:

To be distributed in accordance with the initial distribution number (IDN) 344765, requirements for calibration procedure TB 9-6625-2342-24.



### Instructions for Submitting an Electronic 2028

The following format must be used if submitting an electronic 2028. The subject line must be exactly the same and all fields must be included; however, only the following fields are mandatory: 1, 3, 4, 5, 6, 7, 8, 9, 10, 13, 15, 16, 17, and 27.

From: "Whomever" [whomever@redstone.army.mil](mailto:whomever@redstone.army.mil)  
To: <2028@redstone.army.mil

Subject: DA Form 2028

1. **From:** Joe Smith
2. **Unit:** home
3. **Address:** 4300 Park
4. **City:** Hometown
5. **St:** MO
6. **Zip:** 77777
7. **Date Sent:** 19-OCT-93
8. **Pub no:** 55-2840-229-23
9. **Pub Title:** TM
10. **Publication Date:** 04-JUL-85
11. **Change Number:** 7
12. **Submitter Rank:** MSG
13. **Submitter FName:** Joe
14. **Submitter MName:** T
15. **Submitter LName:** Smith
16. **Submitter Phone:** 123-123-1234
17. **Problem:** 1
18. **Page:** 2
19. **Paragraph:** 3
20. **Line:** 4
21. **NSN:** 5
22. **Reference:** 6
23. **Figure:** 7
24. **Table:** 8
25. **Item:** 9
26. **Total:** 123
27. **Text**

This is the text for the problem below line 27.





